

September 20, 2012

# EGYPTIAN SOLAR THEOLOGY

# LEARNING OBJECTIVES

---

- ✘ Understand the importance of Solar Theology in Ancient Egypt
- ✘ Know the three aspects of the Sun: Khepre, Re and Atum
- ✘ Know the Myth of the Heavenly Cow
- ✘ Know the Myth of Re & Mut
- ✘ Know that 4<sup>th</sup> Dynasty added 'Son of Re' to their titles
- ✘ Know the importance of the Solar Temples of the 5<sup>th</sup> Dynasty kings
- ✘ Know the importance of the sun's daily circuit and the deceased kings of the New Kingdom
- ✘ Know the importance of Amarna Revolution: Akhenaton and the Aten

# SOLAR THEOLOGY

---

- ✘ Egyptian Interest In Nature Was Solar
- ✘ All creation myths have a solar aspect to them
  - + Atum – solar deity and creator god
  - + Ptah creates the sun to bring light

# SOLAR CYCLE OF THE VISIBLE WORLD

- ✘ Khepri – Rising sun in the morning
- ✘ Re - the solar disk of day
- ✘ Atum – ram headed figure of evening

Scarab Beetle



Khepri

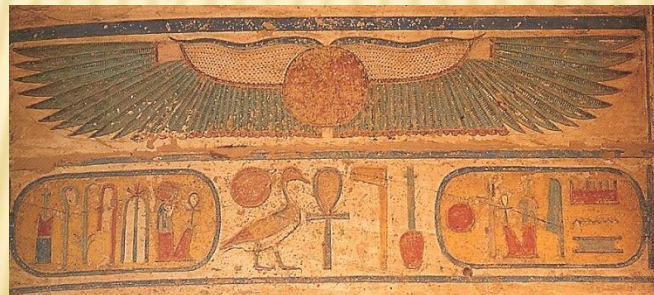

Ra as solar disk

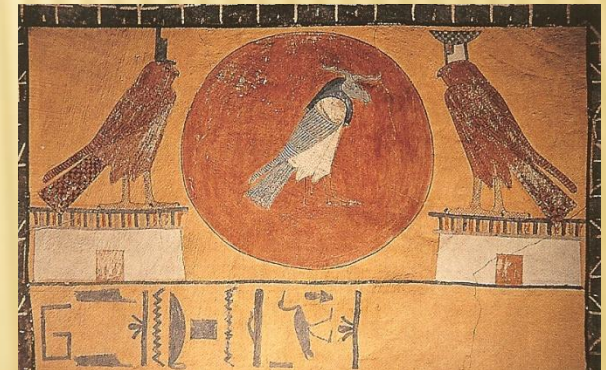

Atum

# MYTH – HEAVENLY COW

---

- ✘ Re was King
- ✘ Humans and gods were still together
- ✘ People plotted against the Re
- ✘ Sent the ‘Eye of Re’ (Hathor or Sekhmet) to destroy the people
- ✘ Had to pacify the ‘Eye of Re’ with ochre colored beer
- ✘ Re retreats to heaven

# ICON – HEAVENLY COW

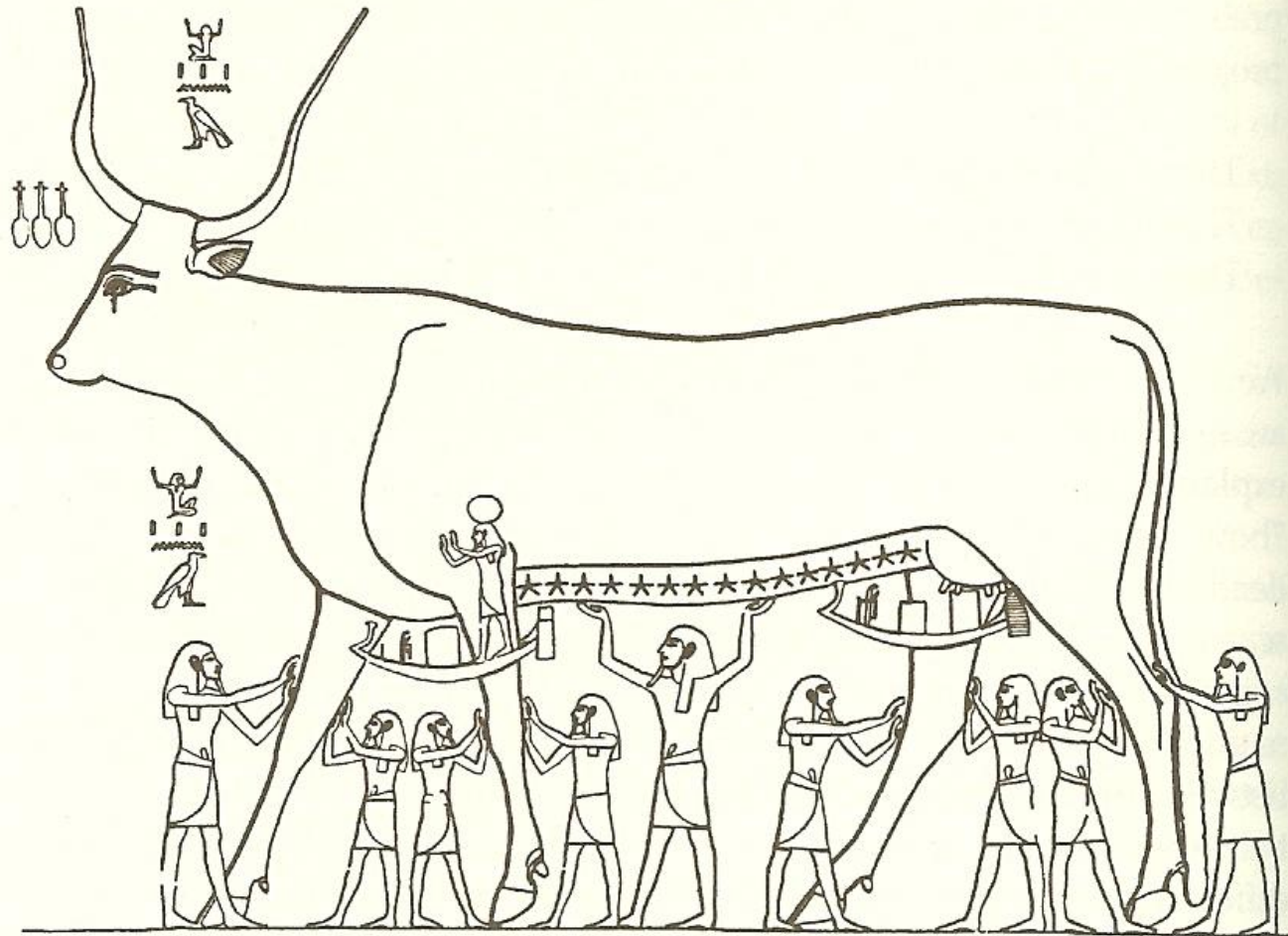

FIGURE 5. The heavenly cow. From A. Piankoff, *The Shrines of Tut-Ankh-Amon*, Bollingen Series 40 (New York, 1955), p. 142, fig. 46.

Jan Assman, *The Search of God in Ancient Egypt*

# SOLAR BARQUE

---

- ✘ Sky was a watery expanse
- ✘ Re traveled the sky in the Solar Barque
- ✘ Major concern of the Egyptians that the sun continues to rise and set

# NUT AND RE

- ✘ Nut (sky goddess) swallows the sun at night and give birth to him in the day

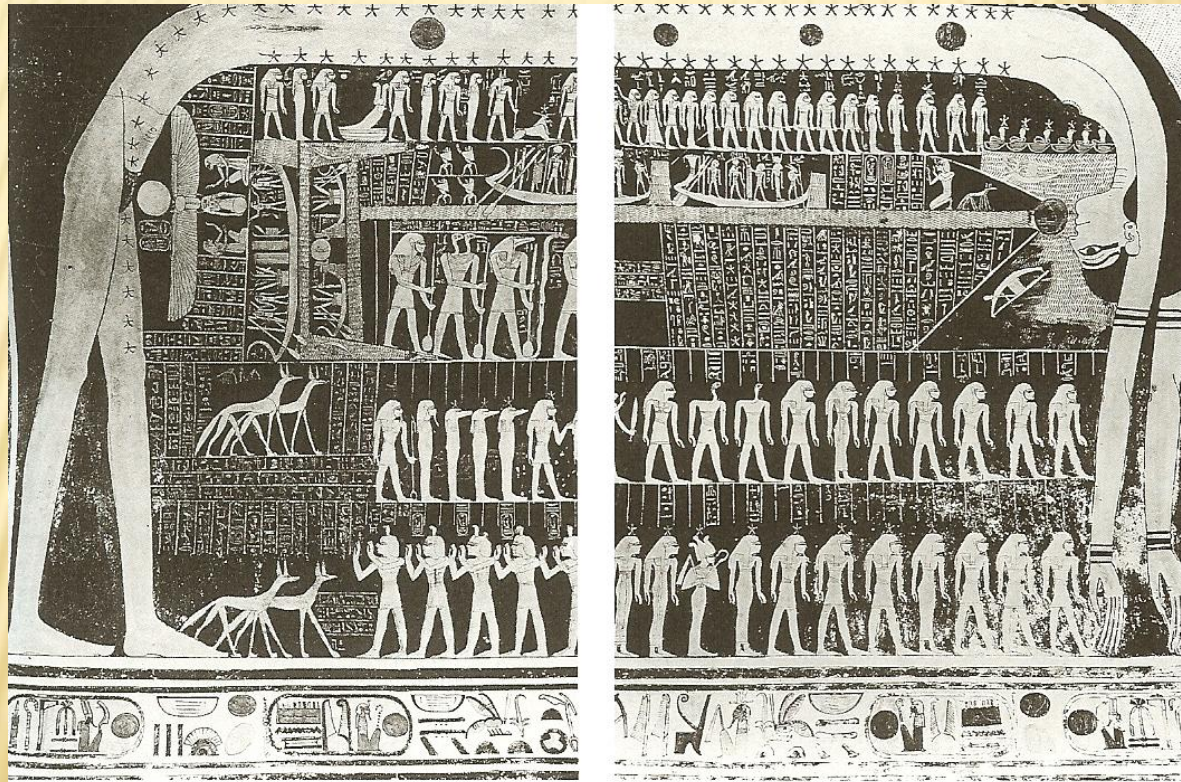

Nicholas Reeves & Richard Wilkinson *The Complete Pyramids*, London: Thames and Hudson, 1997, pg 165

# ORIGINS OF SOLAR THEOLOGY

---

## ✘ Fourth Dynasty Kings

- ✘ “Son Of Re” Part of their titularies – connected with the kings birth name
- ✘ Incorporated Re into their throne names
- ✘ Pyramids
- ✘ Sphinx = Re Harakhty (Re as Horus of the Horizon)
- ✘ Solar Boats

# KHAFRE'S PYRAMID AND THE SPHINX



# SUN TEMPLES

---

- × Fifth Dynasty Kings

- + Myth - First three kings of the fifth dynasty were sired by Re
- + Smaller Pyramids
- + Sanctuaries For The Sun God Re

- × Reflect importance of cult of Re, sun god of Heliopolis

- × Don't know exact function of sun temples

- + Dedicated - aspect of the sun god
- + Religious ceremonies continued for many generations

# NIUSERRE'S SUN TEMPLE



# COURTYARD

- ✘ In courtyard is a huge alabaster alter
- ✘ Rectangular podium, with sides sloping inward, of limestone on a granite platform
  - + Squat limestone obelisk
  - + Sacred symbol of the sun-god

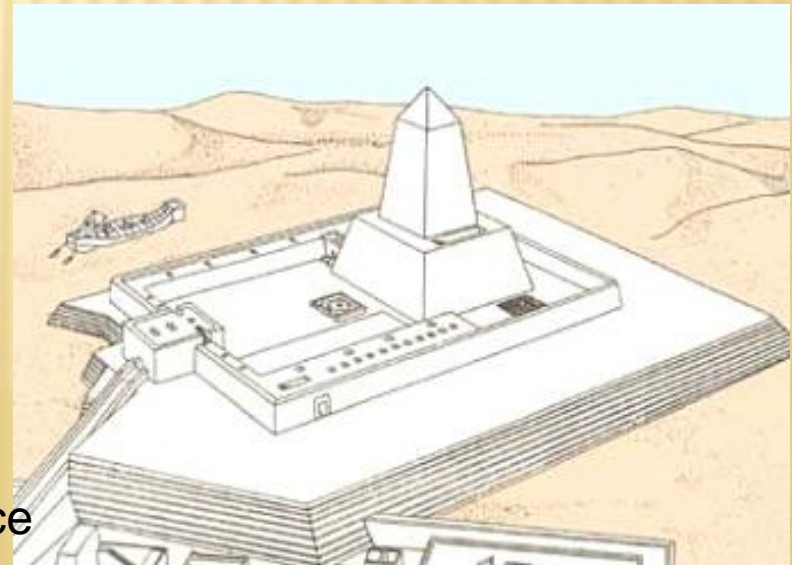

# ALTAR



# BASINS



- ✘ 9 Basins on East Side of Court

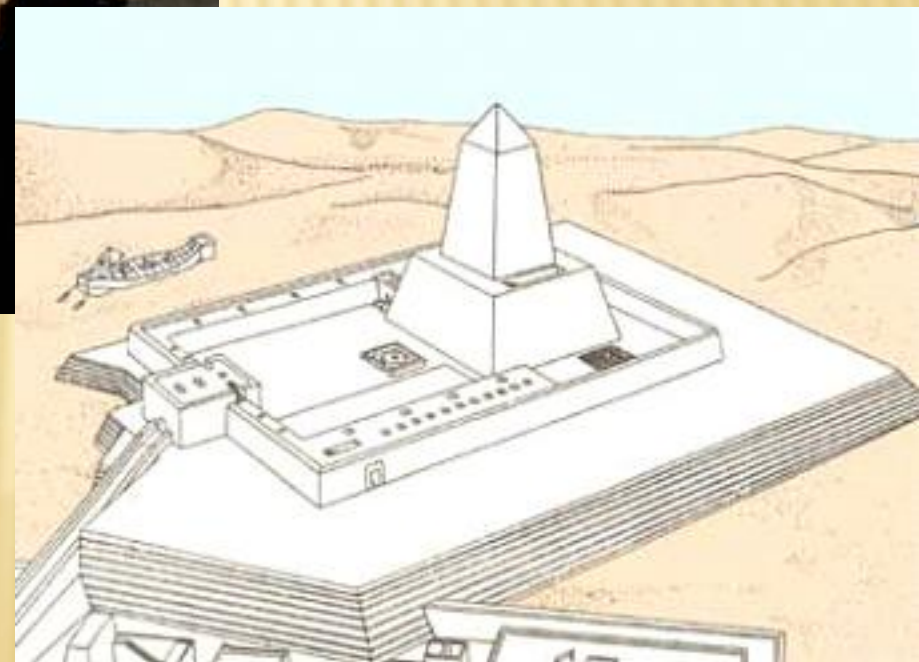

# SUN TEMPLE OBELISK

- ✘ Related to *ben-ben* stone
  - + Temple of Re at Heliopolis
  - + *wben*, meaning to rise
- ✘ Symbolized the sacred mound
- ✘ Possibly - petrified semen of the sun/creator god Re-Atum

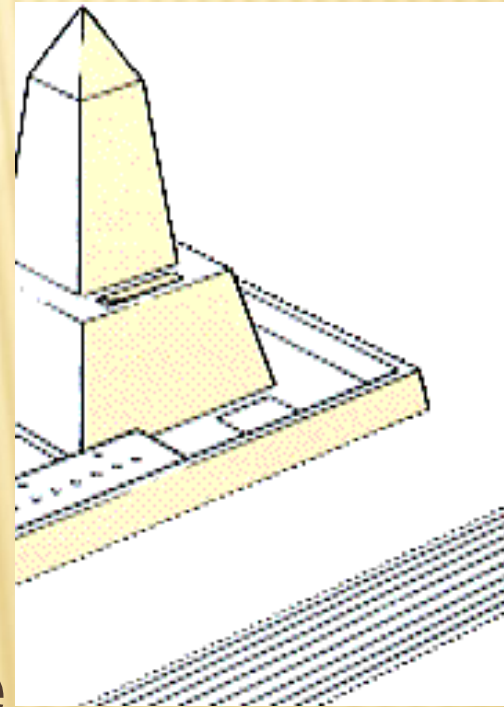

# SUN TEMPLE BOAT

- ✘ South - brick boat, a symbol of Re's daily journey across the sky
- ✘ Hull was built of brick, covered with a layer of painted plaster

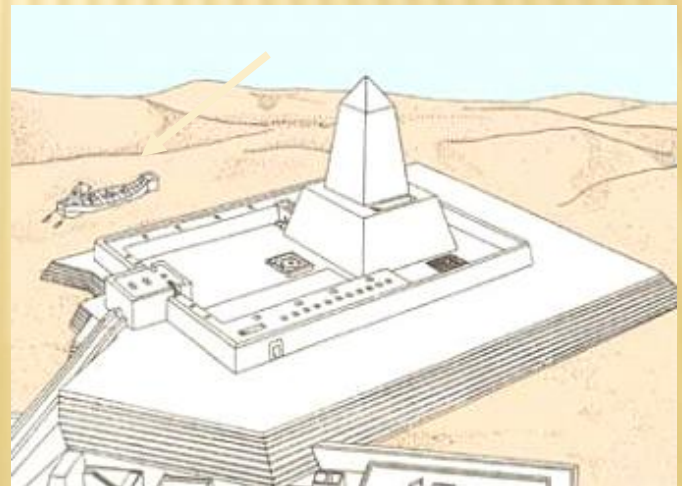

# RELIEFS

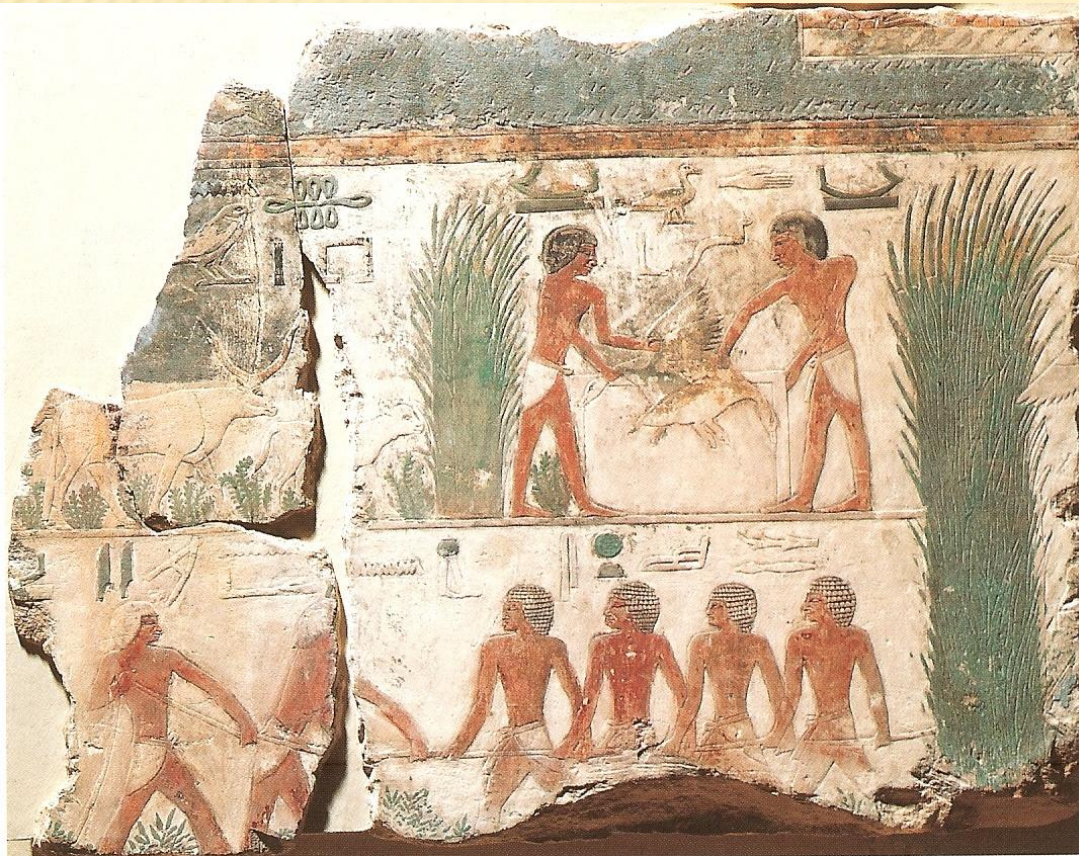

- ✘ Reliefs depicted two of the three seasons
- ✘ *Akhet & Shemu*
- ✘ Scenes showing appropriate activities

Gay Robbins *The Art of Ancient Egypt*. Cambridge, Harvard University Press, 1997, Fig 58

# WELTKAMMER – CHAMBER OF THE WORLD

Sun God is Lord of seasons and provisions

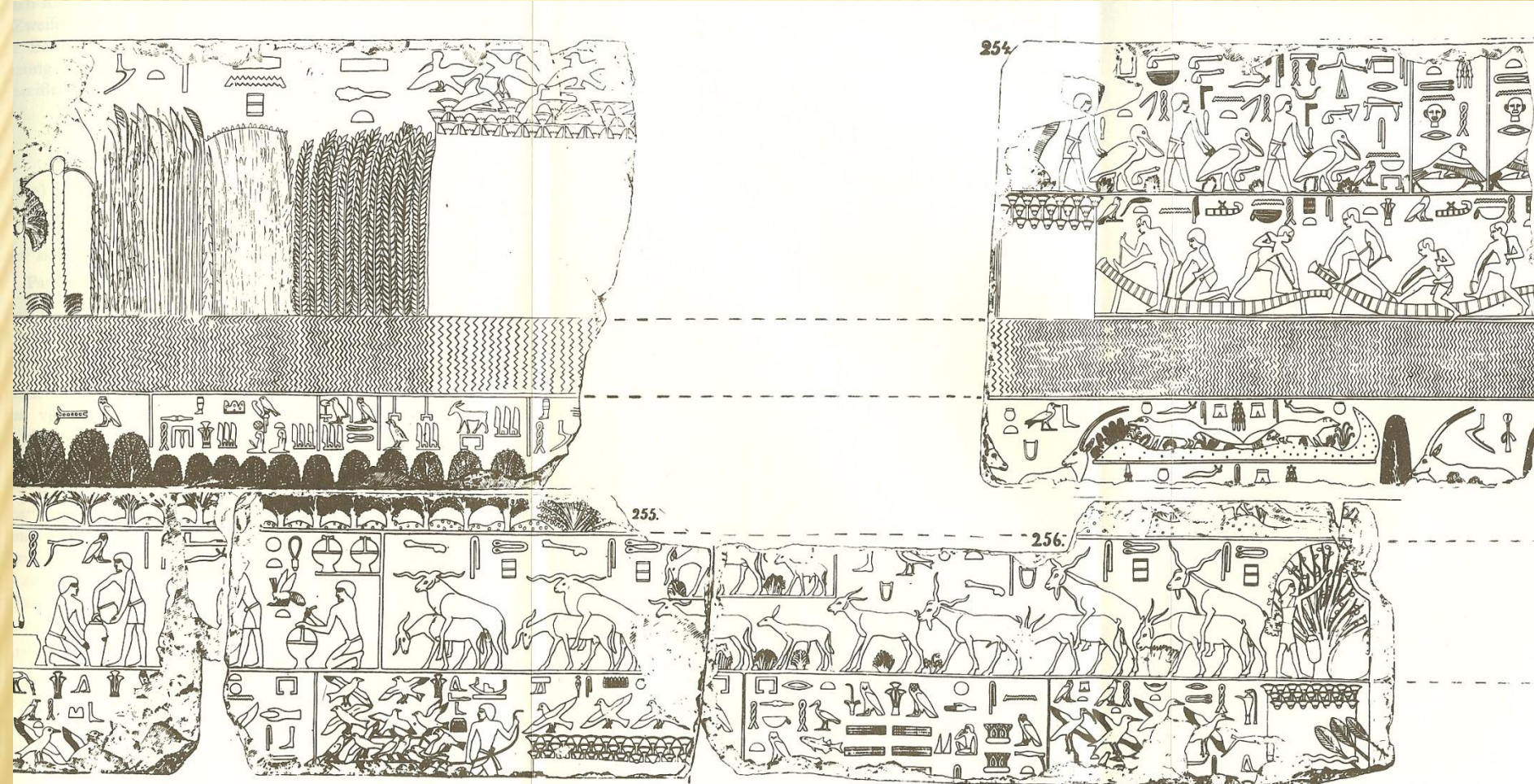

# NEW KINGDOM ROYAL AFTER LIFE BOOKS

- ✘ Tied to the nightly journey of the sun god Amun-Re in the netherworld
  - + Amduat
  - + Book of Gates
  - + Litany of Re

# AMDUAT

---

- ✘ Divides the Netherworld into 12 hours
- ✘ Various entities some are good, some are bad
- ✘ Provides the king with the knowledge he needs to negotiate the afterlife

# AMDUAT THUTMOSE III



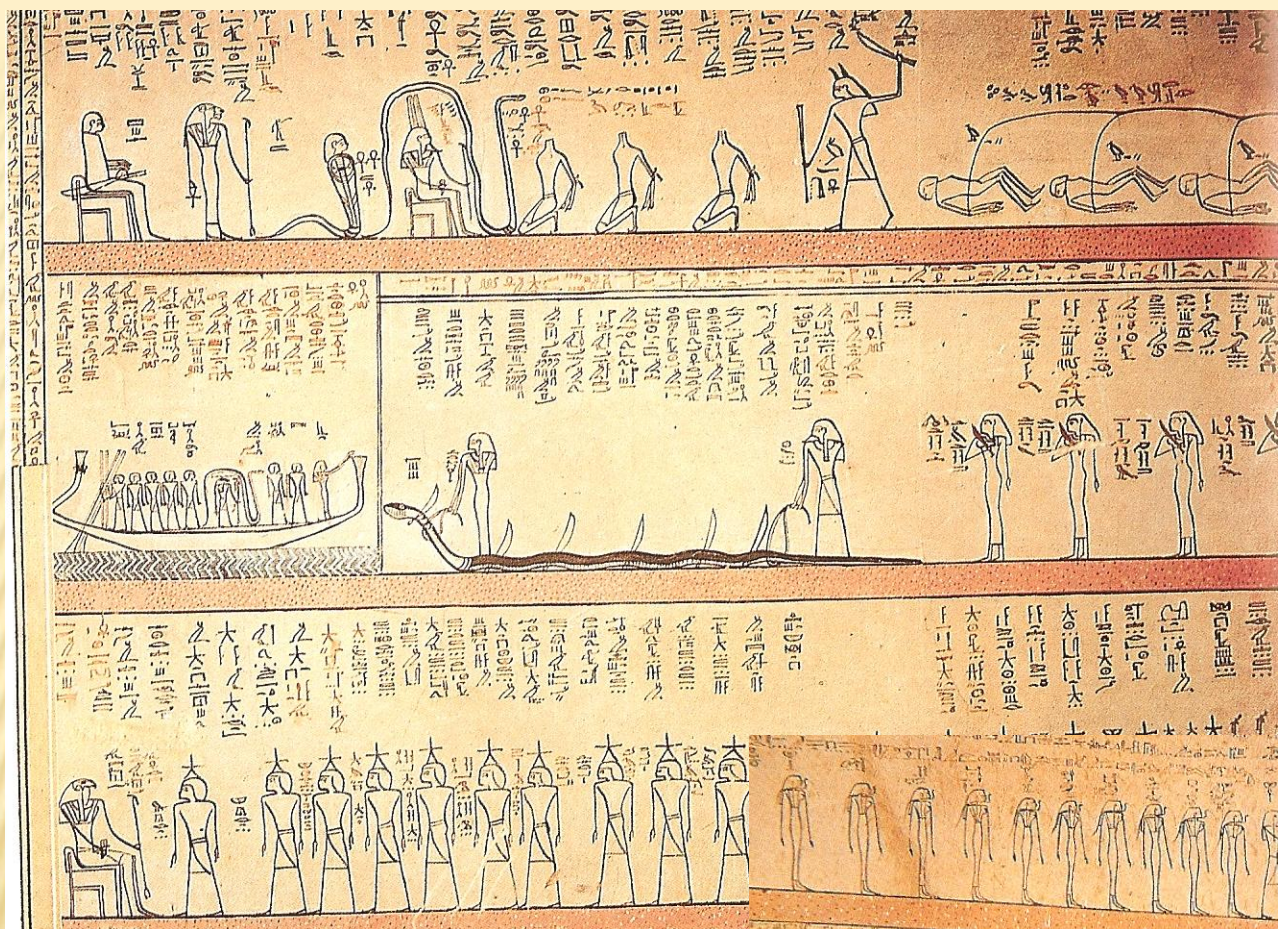

Aphophis Snake must be subdued so the Barque may pass

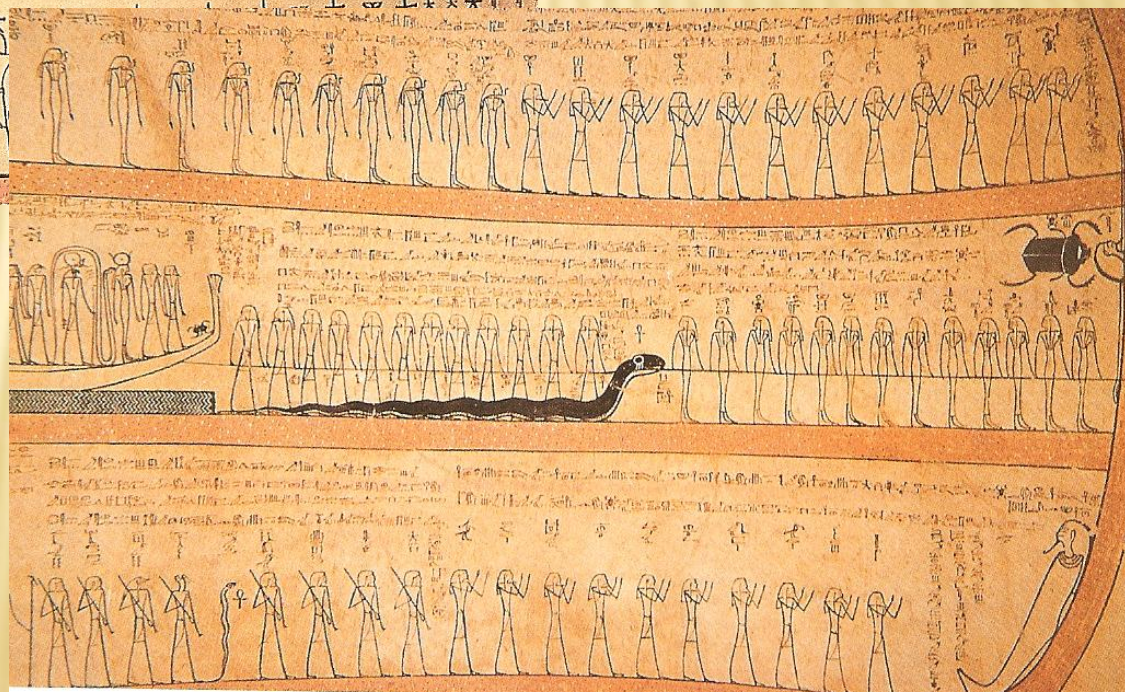

# *BOOK OF GATES* – MID 18<sup>TH</sup> DYNASTY

- ✘ Circa Amenhotep III
- ✘ Night divided into 12 hours/regions
  - + Three registers
  - + Gates depicted at the end of each hour. Fire demons – must know the name of the Gate
- ✘ Emphasis on space or territory

# BOOK OF GATES

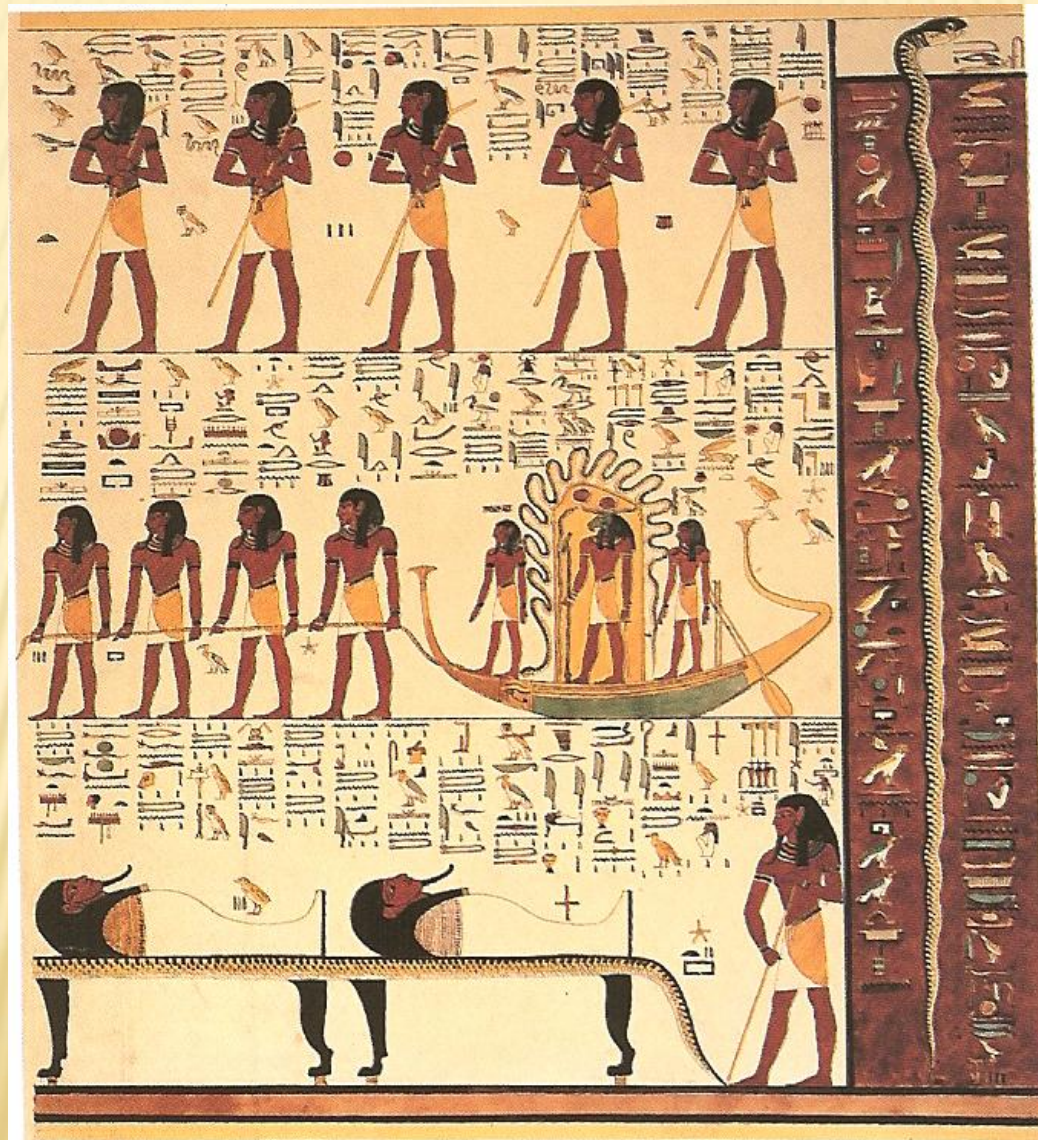

# *LITANY OF RE – MID 18<sup>TH</sup> DYNASTY*

---

- ✘ Derived from Temple texts = 75 names of Re
- ✘ The king is identified with Re
- ✘ Original title “Book of Praying to Re in the West, Praying to the United one in the West”

# LITANY OF RE

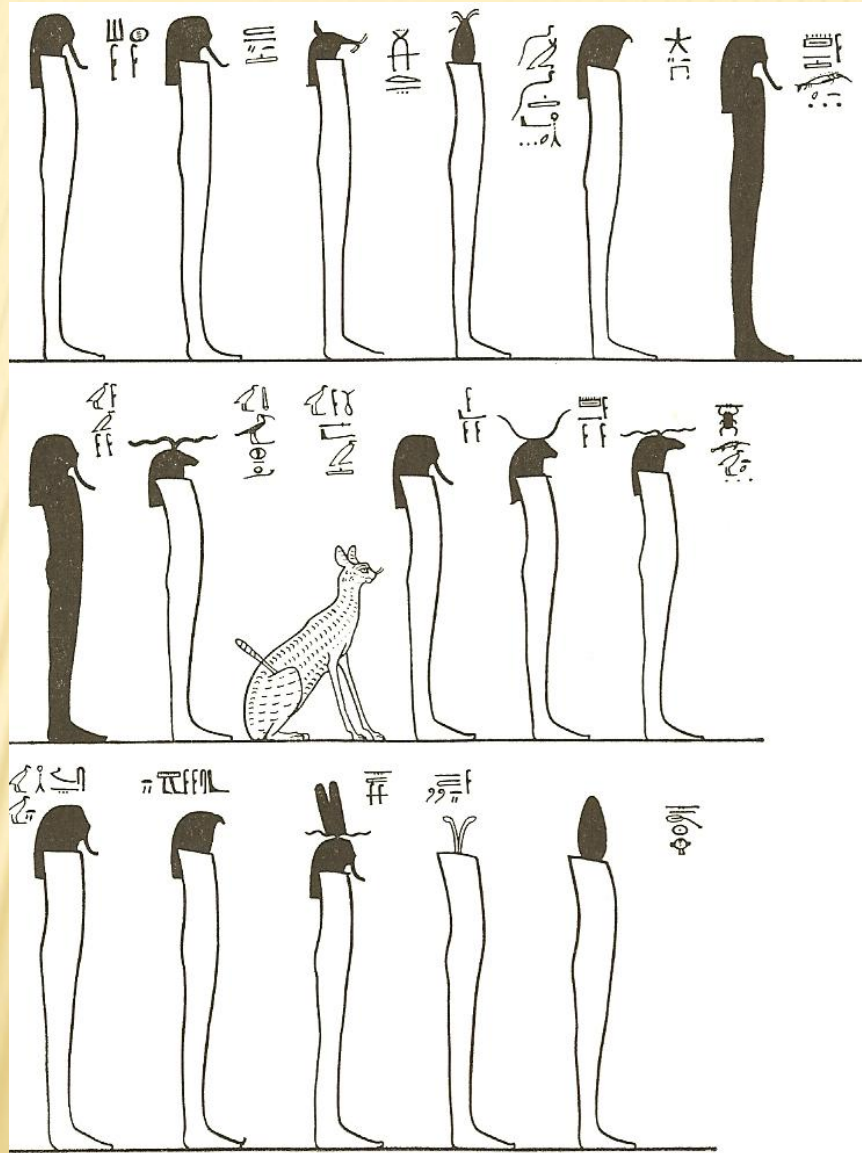

# AMARNA REVOLUTION

---

- ✘ Radical Variant - Solar Theology
- ✘ Lasted 12-15 Years Amenhotep IV/Akhenaten
- ✘ Early in his reign changes his name
- ✘ Polytheism is replaced by Atenism
  - + Often Called The 1<sup>st</sup> Monotheism
  - + Founded Religion = Imposed Religion
- ✘ New Religion Characterized Itself As
  - ✘ Ma'at
  - ✘ Brands everything else as falsehoods

# ATEN – NEW ICONOGRAPHY

---

- ✘ Different Way Of Viewing The God.
- ✘ A Single Image Of The God Aten
- ✘ Worshipped As The Sun – Sole Manifestation
- ✘ No Cult Statues
- ✘ God Shown As A Solar Disk With Arms
- ✘ Shown Only In Constellation With The Royal Couple

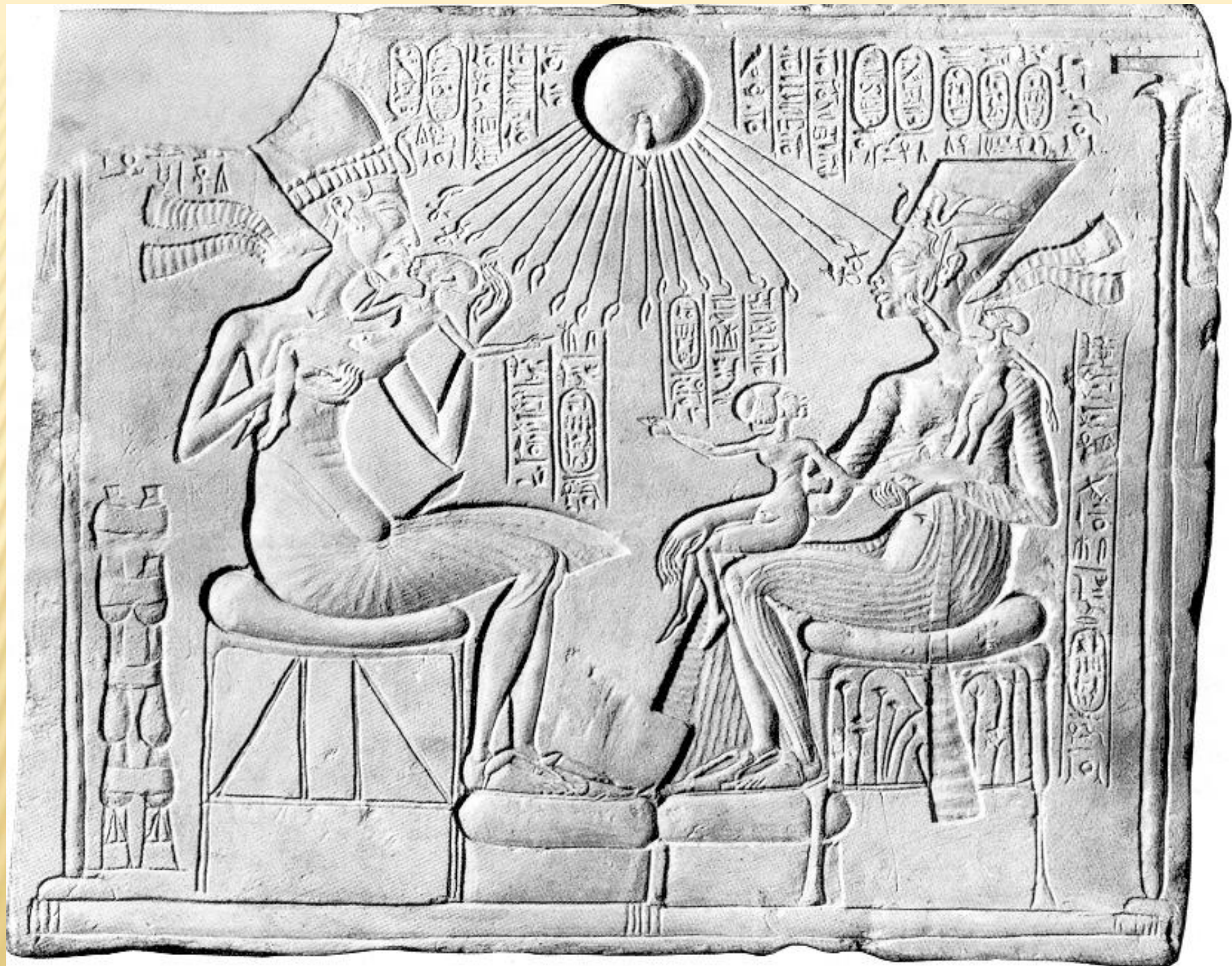

# LEARNING OBJECTIVES

---

- ✘ Understand the importance of Solar Theology in Ancient Egypt
- ✘ Know the three aspects of the Sun: Khepre, Re and Atum
- ✘ Know that 4<sup>th</sup> Dynasty added 'Son of Re' to their titles
- ✘ Know the importance of the Solar Temples of the 5<sup>th</sup> Dynasty kings
- ✘ Know the importance of Amarna Revolution: Akhenaton and the Aten